

WL10-G

WiFi-IT!

KEY FEATURES

- Battery Operation (7.5 µA Sleep Current)
- Small Form Factor (1.3" x 1.8")
- Fully Programmable using WiFi-IT! Basic Language
- Timer and Event Triggered Auto-reporting Capability
- Analog, Digital, Serial and PWM Interfaces
- Multiple Active Interfaces
- Real-Time Clock
- Security: WEP128, WPA-PSK and WPA2-PSK (TKIP / AES)
- Simple Wireless-Wire Mode
- WLAN / TCP/IP Stack Built-in
- UART Interfaces Support Hardware Flow Control
- 40 to +85 °C Operating Temperature Range
- 2.0 volts to 3.3 volts Operating Voltage

**802.11b/g
 Wireless
 Network
 Module**



GENERAL INFORMATION

The WiFi-IT! wireless module is a low cost, easy to integrate, robust solution for providing low to mid-speed WLAN communication. WiFi-IT! is perfectly suited for creating sensor-based 802.11 b/g compatible networks. The module supports a wide range of interfaces including, UART, SPI (master and slave), I2C, Digital, Analog and Pulse Width Modulated (PWM). Multiple active interfaces are supported! WiFi-IT! is compatible with standard 802.11 b/g wireless access points. The WiFi-IT! module is available with an external antenna or an internal antenna.

MODULE BLOCK DIAGRAM

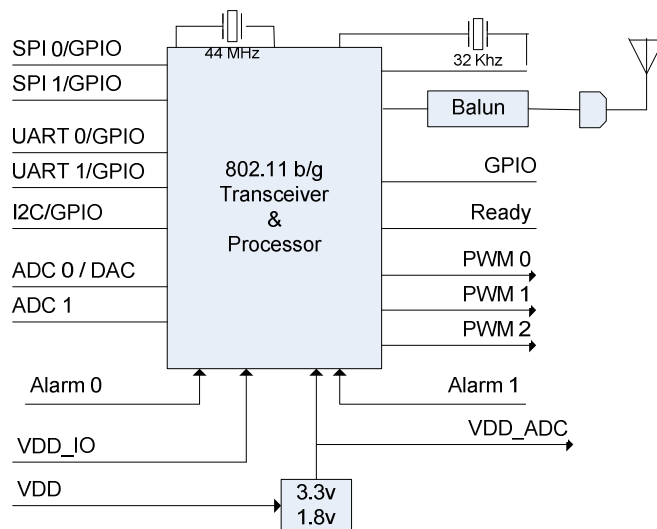

HARDWARE DESCRIPTION

The WiFi-IT module operates in the 2.4 GHz ISM band and supports two standard 802.11 b/g data rates, 1 Mb/s and 2 Mb/s.

The module provides a variety of hardware interfaces that may be active at any time. There are two UARTs, each providing an asynchronous communication interface supporting all standard bit rates up to 921.6 kbps. Both UARTs support hardware flow control, if enabled. Two SPI interfaces provide dual synchronous serial communication and operate in either slave or master modes. SPI 0, when configured as a master device, provides up to four chip selects. One I²C port is provided supporting bit rates up to 392 kbps. Three Pulse-Width Modulation (PWM) outputs are provided. The PWM outputs operate in two modes; as independent function blocks providing an output signal with programmable frequency and duty cycle, or as synchronized PWM function blocks with programmable phase delay between each PWM output. Two ADC inputs provide 10-bit A-to-D conversions at up to 32 ksps. ADC 0 can be configured as a DAC providing 10-bit D-to-A conversions. When ADC 0 is used as a DAC, ADC 1 is disabled and should be left unconnected. Unused pins are available as General Purpose I/O (GPIO), which may be programmed as Input (default), Output or Bi-Directional.

Two Alarm inputs are provided to wake the WiFi-IT from the power conservation sleep mode. The Alarm inputs have programmable polarity and are Schmidt-triggered logic. The Ready output goes active when the module is ready to communicate.

FIRMWARE DESCRIPTION

The WiFi-IT module is available preloaded in two different configurations. The Wireless-Wire (L1) configuration requires no programming, just use the configuration application program to setup your desired operation parameters and the module is ready to connect to legacy or new designs.

The WiFi-IT Basic Language (L2) version is preconfigured with the Basic Language Run-Time Engine (RTE), enabling the engineer to design, code and debug their own applications. WiFi-IT! Basic applications run directly on the WiFi-IT! Module application processor, replacing the external microprocessor in most embedded designs!

WiFi-IT! WIRELESS-WIRE

The Wireless-Wire application supports configuration of a node's interface ports and control engine. It is also used to setup the wireless communication parameters either remotely or through an RS232/USB port on a Personal Computer.

Interface ports can be enabled and configured with the desired operating parameters. The node control engine can be setup to operate in three unique modes:

1. Sleeping sensor node with timer or interrupt auto-reporting.
2. Sleeping data node with timer or interrupt auto-reporting.
3. Always-on node with interrupt, timer or continuous connection.

Once configured the WiFi-IT node permanently stores the settings and will operate, using those settings, until they are changed. The Wireless-Wire Configuration application can update node operating parameters over the wireless network at anytime.

The Wireless-Wire protocol supports UDP communication between the node and an Access Point. Communication between a Microsoft Windows® PC and the WiFi-IT nodes is directly supported through a supplied virtual COM port (vCOM) driver. Once the vCOM port is created the connection to the embedded system containing the WiFi-IT node operates just as a wired connection. Data can be transferred from the embedded system or sent to the embedded system through the vCOM port.

When operating with legacy RS232 equipment, no modifications to the legacy communication protocol need to be made, in many instances. The Wireless-Wire wraps the legacy communication messages in its own protocol for transmission and removes the wrapper before forwarding the communication on to the legacy system.

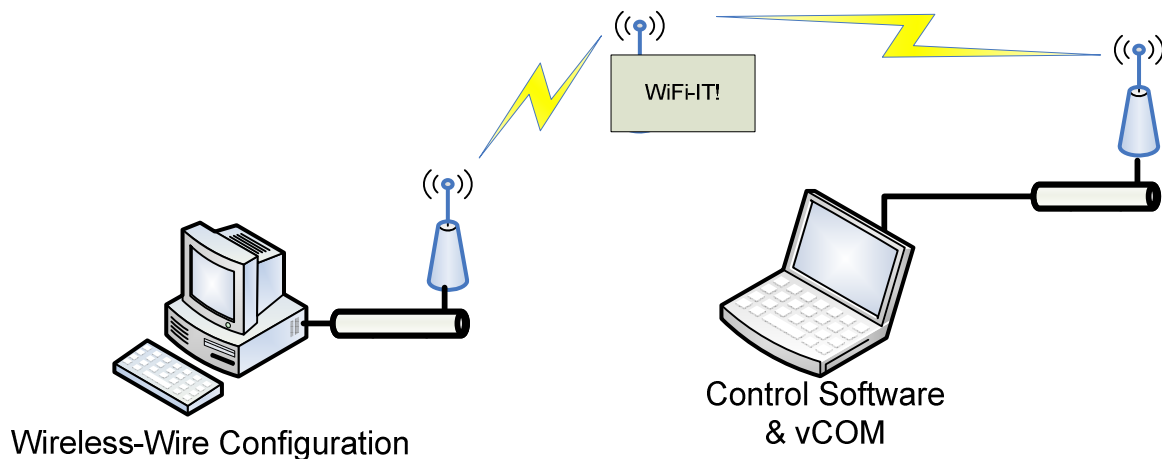

Figure 1: Wireless Wire (L1) System Diagram

When operating in one of the sleep modes there may be a latency period until the node leaves the sleeping state and connects to the WLAN. The vCOM port can be configured to buffer messages until the node is available.

WiFi-IT BASIC PROGRAMMING LANGUAGE

The WiFi-IT Basic programming language provides a higher level of control, allowing the engineer to write code which runs directly on the WiFi-IT! application processor. WiFi-IT Basic comes with its own development environment allowing sophisticated programs to be written providing direct program control of an embedded system. WiFi-IT Basic provides a high-level Application Programming Interface (API) to the wireless LAN, special sleep modes and control of the hardware interfaces. The WiFi-IT development environment provides module configuration tools, a syntax aware editor, the WiFi-IT Basic language compiler, a full featured debugger that operates wired or wirelessly, a program loader and a project manager. Once the application has been verified the code can be burned into as many WiFi-IT! modules as desired. Since programs run on the WiFi-IT! application processor there is no need for an external microprocessor, providing a cost effective wireless solution for the embedded system designer.

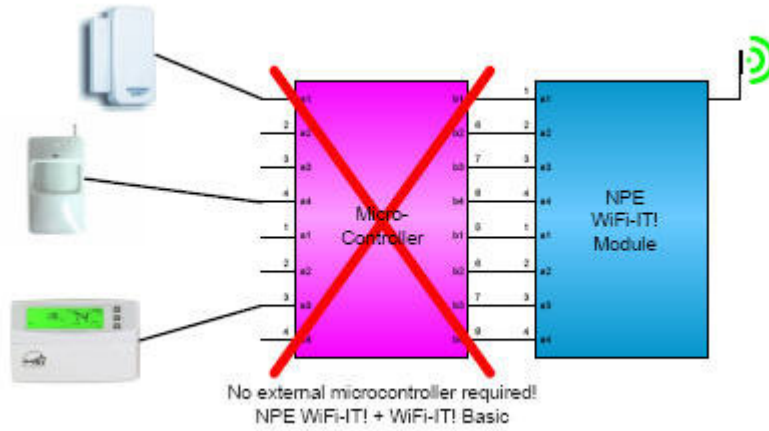
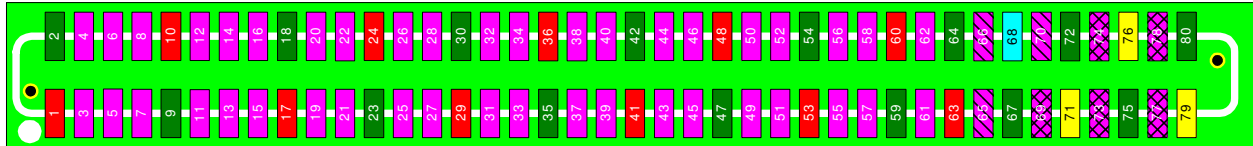

Figure 2: WiFi-IT! Basic Language (L2) Implementation

Pin-out and Signal Description

The following diagram lists the WL10-G signals. The signals are color-coded to indicate functional groups according to their associated interfaces. For I/O signals that share functionality with GPIO pins, the default functional state after reset is GPIO, with pins configured as inputs.



KEY

- VDDIO
- VDDIO referenced signals
- VDD
- VDD referenced signals
- VDDADC
- VDDADC referenced signals
- GND

PIN	SIGNAL	ALTERNATE	I/O	DESCRIPTION	DRIVE
3	TMS ³		I	JTAG Control Input	—
4	TRSTn ³		I	JTAG Reset Input (Active Low)	—
5	TDO		O	JTAG Data Output	4 ma
6	TDI ⁴		I	JTAG Data Input	—
7	CFG0	GPIO_28 ²	I/O	JTAG Configuration 0 Input	4 ma
8	TCK ³		I	JTAG Clock Input	—
11	LED0	GPIO_30	I/O	High Drive Output 0	20 ma
12	CFG1	GPIO_29 ²	I/O	JTAG Configuration 1 Input	4 ma
13	LED1	GPIO_31	I/O	High Drive Output 1	20 ma
14	UART0_CTS \ READY	GPIO_24	I/O	UART 0 Clear to Send Input \ Alarm Wake-up Ready	4 ma
15	UART0_RX	GPIO_00	I/O	UART 0 Receive Data Input	4 ma
16	UART0_RTS	GPIO_25	I/O	UART 0 Request to Send Output	4 ma
19	UART1_TX	GPIO_02	I/O	UART 1 Transmit Data Output	4 ma
20	UART0_TX	GPIO_01	I/O	UART 0 Transmit Data Output	4 ma
21	UART1_RX	GPIO_03	I/O	UART 1 Receive Data Input	4 ma

PIN	SIGNAL	ALTERNATE	I/O	DESCRIPTION	DRIVE
22	UART1_CTS	GPIO_26	I/O	UART 1 Clear to Send Input	4 ma
25	SSPI_DIN		I	SPI Slave Data Input	4 ma
26	UART1_RTS	GPIO_27 ¹	I/O	UART 1 Request to Send Output	4 ma
27	SSPI_CS		I	SPI Slave Chip Select Input	4 ma
28	AUXSNAP0	GPIO_16	I/O	Auxiliary Snapshot 0 Input	4 ma
31	SSPI_CLK		I	SPI Slave Clock Input	4 ma
32	SSPI_DOUT		I/O	SPI Slave Data Output	4 ma
33	I2C_DATA	GPIO_08	I/O	I2C Data	12 ma
34	I2C_CLK	GPIO_09	I/O	I2C Clock	12 ma
37	AUXSNAP1	GPIO_17	I/O	Auxiliary Snapshot 1 Input	4 ma
38	PWM0	GPIO_10	I/O	Pulse Width Modulated Output 0	4 ma
39	PWM1	GPIO_11	I/O	Pulse Width Modulated Output 1	4 ma
40	AUXTARGET	GPIO_18	I/O	Auxiliary Target Output	4 ma
43	PWM2	GPIO_12	I/O	Pulse Width Modulated Output 2	4 ma
44	CLK0_44MHz	GPIO_19	I/O	44 MHz Clock Output	4 ma
45	CLK_11MHz	GPIO_21	I/O	11 MHz Clock Output	4 ma
46	CLK0_22MHz	GPIO_20	I/O	22 MHz Clock Output	4 ma
49	CLK_LP	GPIO_22	I/O	Low Power Clock Output	4 ma
50	PPS	GPIO_23	I/O	Pulse Per Second Output	4 ma
51	MSPI_CS1	GPIO_13	I/O	SPI Master Chip Select 1 Output	4 ma
52	MSPI_CS0	GPIO_04	I/O	SPI Master Chip Select 0 Output	4 ma
55	MSPI_CLK	GPIO_05	I/O	SPI Master Clock Output	4 ma
56	MSPI_DOUT	GPIO_07	I/O	SPI Master Data Output	4 ma
57	MSPI_CS2	GPIO_14	I/O	SPI Master Chip Select 2 Output	4 ma
58	MSPI_CS3	GPIO_15	I/O	SPI Master Chip Select 3 Output	4 ma
61	RESETn		I/O	External Reset Output / Module Reset Input	—
62	MSPI_DIN	GPIO_06	I/O	SPI Master Data Input	4 ma
65	NC		—	DO NOT CONNECT	—
66	ADC2 ⁵	VREF	I	ADC Channel 2 Input / Reference Voltage Input	—
69	DC_CTRL ⁶		O	DC-to-DC Regulator Control Output	4 ma
70	ADC1 ⁵	DAC	I/O	ADC Channel 1 Input / DAC Output	—

PIN	SIGNAL	ALTERNATE	I/O	DESCRIPTION	DRIVE
73	RTC_OUT2 ⁶	CLK_OUT	O	Sensor Wake Real-Time Clock Output 2 / Low Power Clock	4 ma
74	ALARM2 ⁶		I	Wake-Up Input 2	—
77	ALARM1 ⁶		I	Wake-Up Input 1	—
78	RTC_OUT1 ⁶		O	Sensor Wake Real-Time Clock Output 1	4 ma

Table 1: Interface Signal Description

NOTES

1. If GPIO_27 is pulled high during boot, the module will enter program update mode and wait for FLASH download via SSPI or UART 0.
2. GPIO_28 and GPIO_29 are sampled at reset to establish the JTAG configuration for debugging. These signals should only be used as outputs and not be driven by an external device.
3. Configured as input with pull-up active.
4. JTAG TDI is not equipped with a pull-up or pull-down resistor. It should not be left floating.
5. Referenced to VDD_ADC.
6. Referenced to VDD.

GENERAL NOTES

All I/O signals are configured as inputs with pull-down active after power-up or reset. Unless otherwise noted all signals are referenced to VDD_IO.

WL10-G ABSOLUTE MAXIMUM RATINGS

RATING	VALUE	UNITS
VDD IO Supply Voltage Range	3.0 to 3.6	V
VDD Supply Voltage Range	1.8 to 3.0	V
Operating Ambient Temperature Range	-40 to +85	°C
Storage Temperature	-55 to +125	°C

WL10-G ELECTRICAL CHARACTERISTICS

RATING	SYM	MINIMUM	TYPICAL	MAXIMUM	UNITS	NOTES
Supply Voltage Range	VDD_IO	3.0	3.3	3.6	V	1,3
	VDD	2.0	2.7	3.0	V	1,2
	VDD_ADC	0		1.9	V	4
VDD_IO	V _{OH}	VDD_IO - 0.4		VDD_IO	V	5
VDD_IO	V _{OL}	0		0.4	V	5

RATING	SYM	MINIMUM	TYPICAL	MAXIMUM	UNITS	NOTES
VDD_IO	V _{IH}	0.8 VDD_IO			V	5
VDD_IO	V _{IL}			0.25 VDD_IO	V	5
VDD	V _{OH}	VDD - 0.4		VDD	V	6
VDD	V _{OL}	0		0.4	V	6
VDD	V _{IH}	0.8 VDD			V	6
VDD	V _{IL}			0.25 VDD	V	6
VDD_ADC	V _I	0		VDD_ADC - 0.036		7,8
Receive Mode Current				150	mA	
Transmit Mode Current				200	mA	
Sleep Mode Current				7.5	µA	

NOTES:

1. VDD_IO and VDD are generated by the host board.
2. The values of VDD minimum maybe higher in some applications depending on the required value for V_{IH} of the VDD_IO power supply enable.
3. Lower VDD_IO voltages are possible in some applications. Contact NPE, Inc. for further information.
4. VDD_ADC is generated on the WL10-G and has a nominal value of 1.8v.
5. See Table 1 for signals referenced to VDD_IO.
6. See Table 1 for signals referenced to VDD.
7. See Table 1 for signals referenced to VDD_ADC.
8. An external resistor divider can be used to expand the input range of the ADC inputs.

WL10-G RF CHARACTERISTICS

RATING	MINIMUM	TYPICAL	MAXIMUM	UNITS	NOTES
Operating Frequency Range	2412		2484	MHz	
RF Data Rates	1 to 2			Mb/s	
Number of RF Channels		14			
RF Transmit Power		10		mW	
Receiver Sensitivity:				dBm	
1 Mb/S Data Rate		-92			
2 Mb/S Data Rate		-90			
Antenna Impedence		50		Ω	

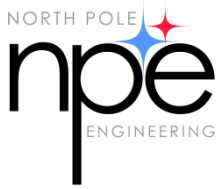

WiFi-IT MODULE PLACEMENT

The WiFi-IT module is available in two antenna configurations; internal chip antenna (WL10-GC) and SMA antenna (WL10-GS) configuration. When using the WL10-GC care must be taken to minimize signal loss. The chip antenna should be clear of any metallic components, copper traces, internal layers and any ground or voltage planes. There should be at least a 5 mm clearance in all directions.

The WL10-GC module should not be enclosed in a metal enclosure.

FCC LABELING INSTRUCTIONS

When installing the WiFi-IT! module into equipment, the module FCC ID number must be visible. If it is not visible then labeling that is clearly visible must be attached to the product stating;

WL10-GS "Contains FCC ID: XRH-1997"

WL10-GC "Contains FCC ID: XRH-1997"

WiFi-IT MODULE CERTIFICATION

The WiFi-IT! module has been certified by the FCC as a module that may be used in OEM equipment without requiring re-certification as an FCC Class C device. To maintain this certification the WiFi-IT! module must use only one of the two following antennas.

MANUFACTURER	ANTENNA GAIN	PART NUMBER	DESCRIPTION
Taoglas	1.8 DbI	GW.11.A153	84 mm Hinged SMA Reverse Male Straight Connector
Antenna Factor	0.5 DbI	ANT-2.45-CHP-T	2.45GHz Chip Antenna

ORDERING INFORMATION

The WiFi-IT module can be ordered with or without firmware loaded in either of two antenna configurations.

PART NUMBER	DESCRIPTION
WL10-GS	SMA antenna version (no firmware loaded).
WL10-GS-L1	SMA antenna version with Wireless-Wire firmware.
WL10-GS-L2	SMA antenna version with the WiFi-IT! Basic RTE.
WL10-GC	Chip antenna version (no firmware loaded).
WL10-GC-L1	Chip antenna version the with Wireless-Wire engine.
WL10-GC-L2	Chip antenna version with the WiFi-IT! Basic RTE.

OUTLINE AND MOUNTING DIMENSIONS

The figure shown below displays the WL10-GC module dimensions in inches.

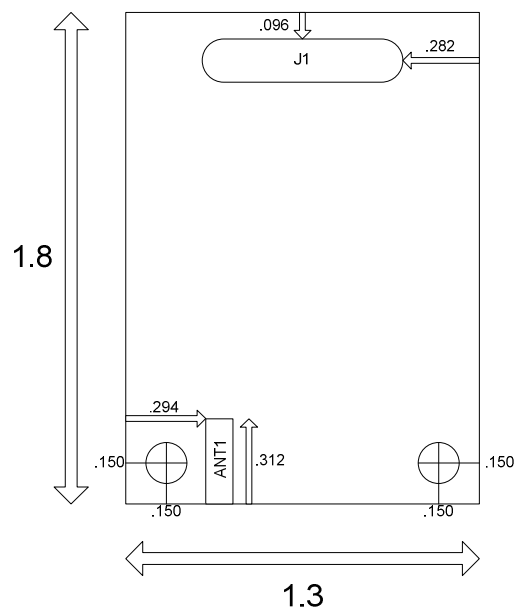

All Dimensions given in inches

CONNECTOR PART NUMBERS

The WiFi-IT J1 connector is Molex part number 0544-770808. This connector mates to Molex part number 0553-390808.

WiFi-IT CONNECTOR MATING

When attaching the module to the embedded system, please follow the instructions shown in diagram A.

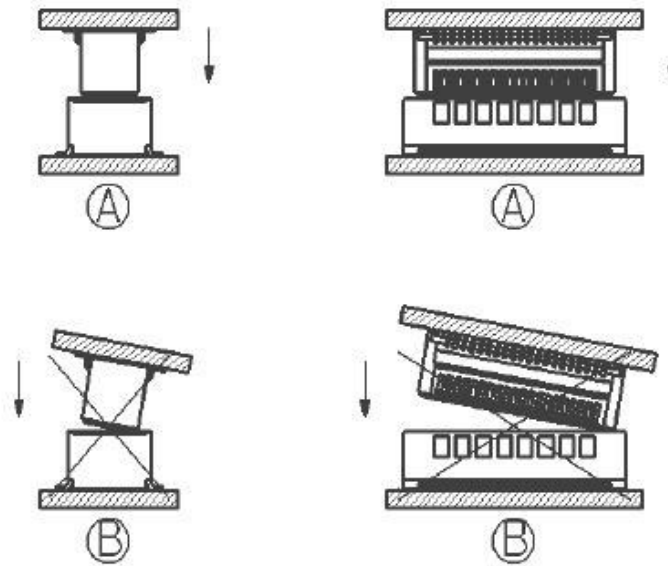

TYPICAL CIRCUITS

The following schematic shows a typical example of a WiFi-IT! compatible power supply designed for both battery and/or wall transformer operation. The power supply will operate under control of the WiFi-IT! module, through the signal RTC_DC_DC_CNTL, to minimize power usage.

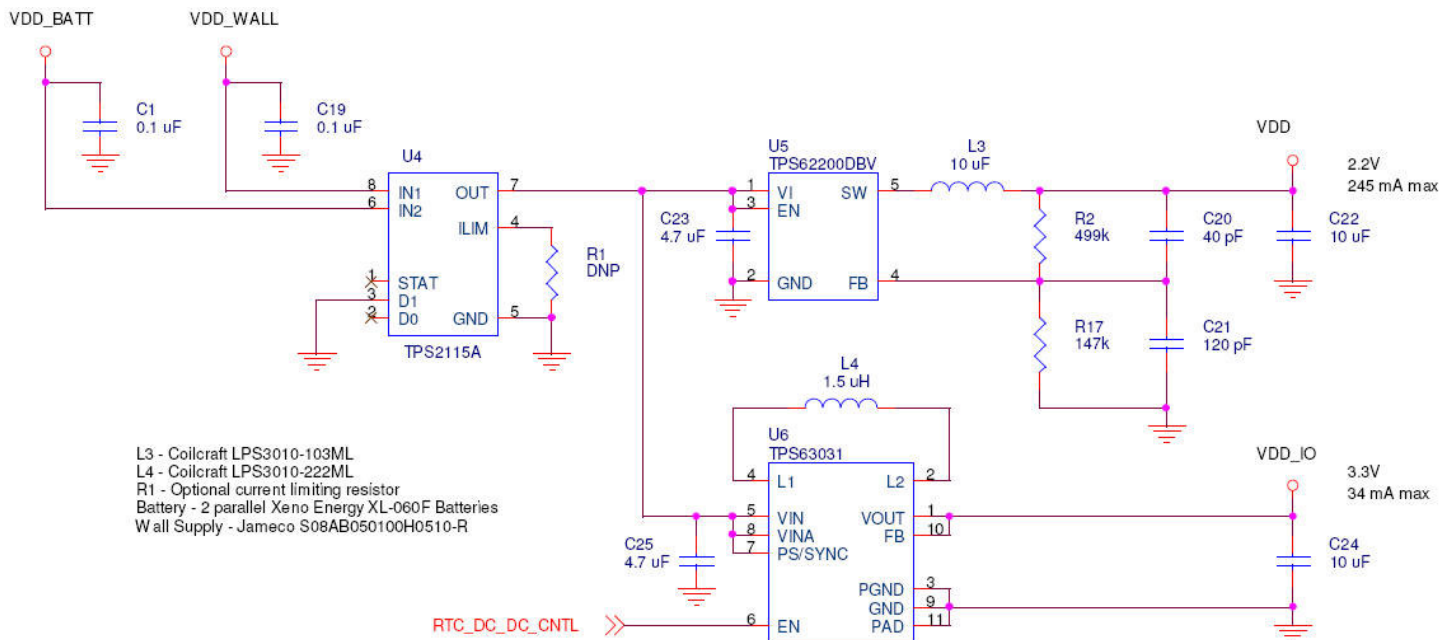

The Bill of Materials (BOM) consists of:

IDENTIFIER	QTY	PART NO.	DESCRIPTION
U4	1	TPS2115A	TI Auto-switching Power Mux
U5	1	TPS62200DBV	TI DC-DC Step Down Converter
U6	1	TPS63031	TI Buck-Boost Converter
L3	1	LPS3010-103ML	Coilcraft Low Profile Shielded Inductor
L4	1	LPS3010-222ML	Coilcraft Low Profile Shielded Inductor
C1, C19,	2	0.1 uF	Capacitor
C23, C25	2	4.7 uF	Capacitor
C20	1	40 pF	Capacitor
C21	1	120 pF	Capacitor
C22, C24	2	10 uF	Capacitor
R2	1	499k	Resistor
R17	1	147k	Resistor

ENGINEER'S DESIGN CHECKLIST

This design checklist should be reviewed before committing a design to PCB fabrication. The checklist contains items that affect performance and/or operation of the WiFi-IT! module.

ITEM	DESCRIPTION	Y/N
1	ALARM1 is pulled high or low through a pull up or pull down resistor. If pulled high, the signal must be pulled to VDD.	
2	ALARM2 is pulled high or low through a pull up or pull down resistor. If pulled high, the signal must be pulled to VDD.	
3	DC_DC_CNTRL is pulled low to GND.	
4	EXT_RESETn is pulled high to VDD_IO.	
5	JTAG_NTRST is pulled low to GND.	
6	JTAG_TDI is pulled high to VDD_IO.	
7	JTAG_TMS is pulled high to VDD_IO.	
8	JTAG_TCK is pulled high to VDD_IO.	
9	JTAG_TDO is pulled high to VDD_IO.	
10	JTAG_CFG [0] (GPIO28) is pulled high to VDD_IO, or low to GND.	
11	JTAG_CFG [1] (GPIO29) is pulled high to VDD_IO, or low to GND.	
12	GPIO27 is pulled high to VDD_IO, and low to GND.	
13	VDD traces and vias to the WiFi-IT! connector are sized to carry 200 mA per connector pin. Two vias per WiFi-IT! connector VDD pin may be necessary.	
14	At least six 0.1 uF bypass capacitors are placed within 0.250" of the WiFi-IT! connector between VDD_IO and GND.	

15	At least two 0.1 uF bypass capacitors are placed within 0.250" of the WiFi-IT! connector between VDD and GND.	
16	At least one 0.1 uF bypass capacitor(s) are placed within 0.250" of the WiFi-IT! connector between 1.8V_ADC and GND.	
17	A power supply capable of supplying 300 mA peak current to the WiFi-IT! is provided over VDD.	
18	A power supply capable of supplying 100 mA peak current at 3.3 volts over VDD_IO, plus any other current requirements of the PCARD. This power supply voltage must be enabled with the GainSpan GS1010's DC_DC_CNTRL signal.	
19	All I/O connecting to VDD_IO referenced signals on the GS1010 are held low whenever the GS1010 drives DC_DC_CNTRL low. This will protect against possibility of causing latch-up in the GS1010.	
20	All I/O connecting to VDD_IO referenced signals on the GS1010 meet the minimum and maximum voltage specification of the GS1010.	

WiFi-IT! EDK - EVALUATION AND DEBUG DEVELOPMENT SYSTEM

The EDK evaluation and debug development system allows you to evaluate and develop Wireless-Wire and WiFi-IT Basic applications using the WiFi-IT! module. Using a Microsoft Windows® based application; you can configure WiFi-IT! modules, running Wireless-Wire firmware and write and debug your own application code on modules running WiFi-IT! Basic.

The EDK platform provides power, easy access to all of the WiFi-IT! interfaces and visual indication of interface signaling, thereby reducing the need for an oscilloscope and/or logic analyzer. In addition, the EDK supports access to the WiFi-IT!'s UART0 through the onboard RS232 interface for setting configuration information, loading code and debugging programs.

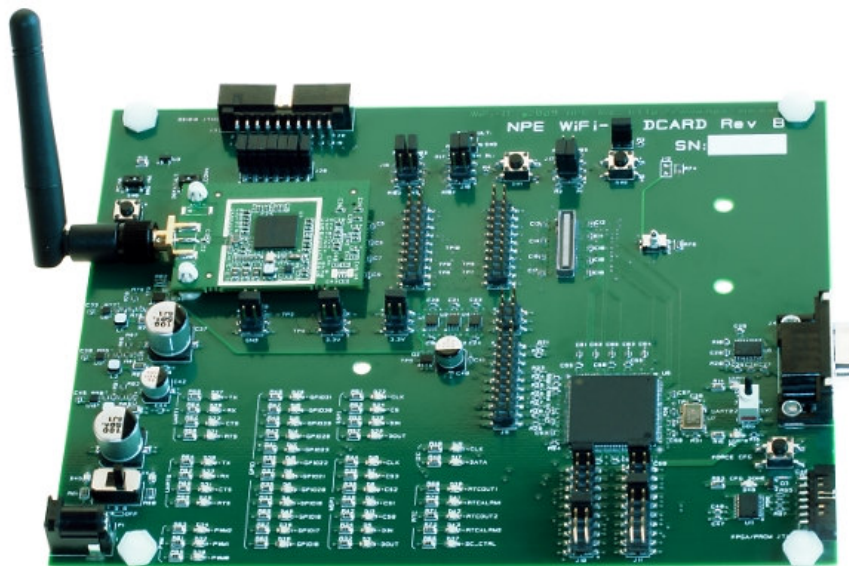

To evaluate the WiFi-IT! modules, NPE provides a configuration and administration program which runs on Microsoft Windows based PCs and operates through a wired or wireless connection. Configuration information is stored directly on the WiFi-IT! module, once configured the node boots to that configuration when powered up.

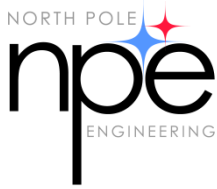

WiFi-IT!™
WLAN Module

WL10-G

The EDK contains two WiFi-IT! Modules – WL10-GS and WL10-GC, the EDK platform board, a code limited version of WiFi-IT! Basic and all cables and power adaptors. A full description of the EDK development system is available from North Pole Engineering, Inc. at our website – www.npe-inc.com.

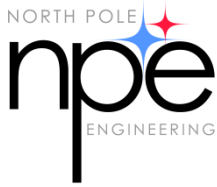

REVISION HISTORY

VERSION	DATE	DESCRIPTION
1.0	Aug. 9, 2009	Initial release version.
1.1	Aug. 10, 2009	Added pin-out graphic. Other minor modifications.
1.2	Aug. 28, 2009	Update firmware description.
1.3	Sept. 25, 2009	Added FCC labeling instructions.
1.4	Jan. 22, 2010	Updated the chip antenna part number to include the 'T' suffix. General updates to the WiFi-IT! Basic Language description.

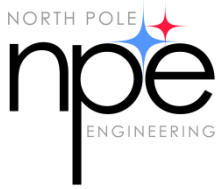

WiFi-IT!™
WLAN Module

WL10-G

IMPORTANT NOTICE

The information included here is provided by North Pole Engineering, Inc. (NPE) and is believed to be accurate and reliable. However, NPE assumes no responsibility for its use, nor any infringement of patents or other rights of third parties, which may result from its use. No license is granted by implication or otherwise under any patent rights of NPE other than for circuitry embodied in NPE's products. This document and described circuitry is subject to change without notice.

The software described in this document is furnished under a license agreement and may be used only in accordance with the terms of the license agreement. No part of this document may be reproduced or transmitted in any form or by any means, electronic or mechanical, without the express written consent of NPE.

Copyright 2009, North Pole Engineering, Inc. All Rights Reserved.